

# FOOT VALVE

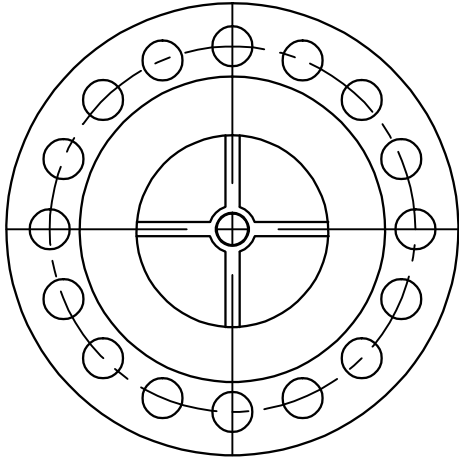

BS 4054 PN16 FOOT VALVE

DIAMETER:DN50-DN200

FACE TO FACE END : BS 4054 PN16

INSPECTION AND TEST:API598

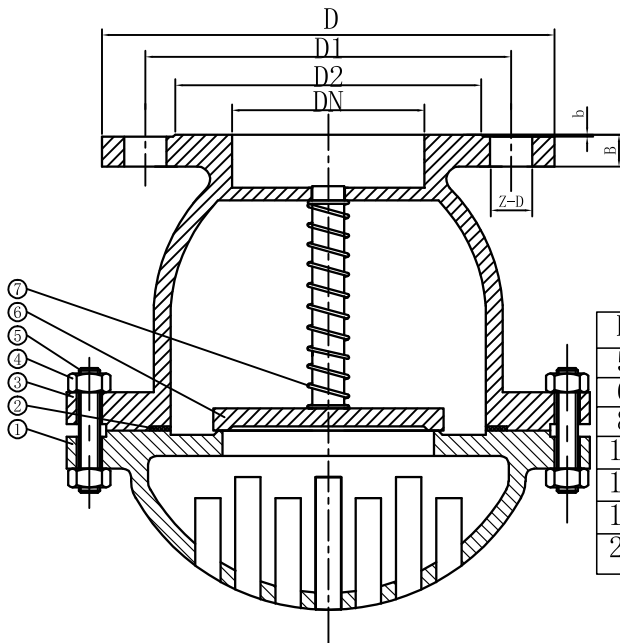

Performance List		
Class	PN16	
Test	Shell Test	2.4
	Back seal Test	1.8
	Seal Test	
	Air Seal	0.6
Temp.	<120°C	

### MAIN SIZE:

DN	D	D <sub>1</sub>	D <sub>2</sub>	B	b	Z-φD
50	160	125	100	18	3	4-18
65	180	145	120	20	3	4-18
80	195	160	135	20	3	4-18
100	215	180	155	22	3	8-18
125	245	210	185	24	3	8-18
150	280	240	210	24	3	8-23
200	335	295	265	24	3	8-23

### MAIN PARTS MATERIALS:

Item No.	PARTS NAME	Test Medium
1	CAP	304
2	PACKING	PTFE
3	BODY	304
4	NUT	A2-70
5	BOLT	A2-70
6	DISC	304
7	SPRING	304