

10" Z541Y-1500LbI-00

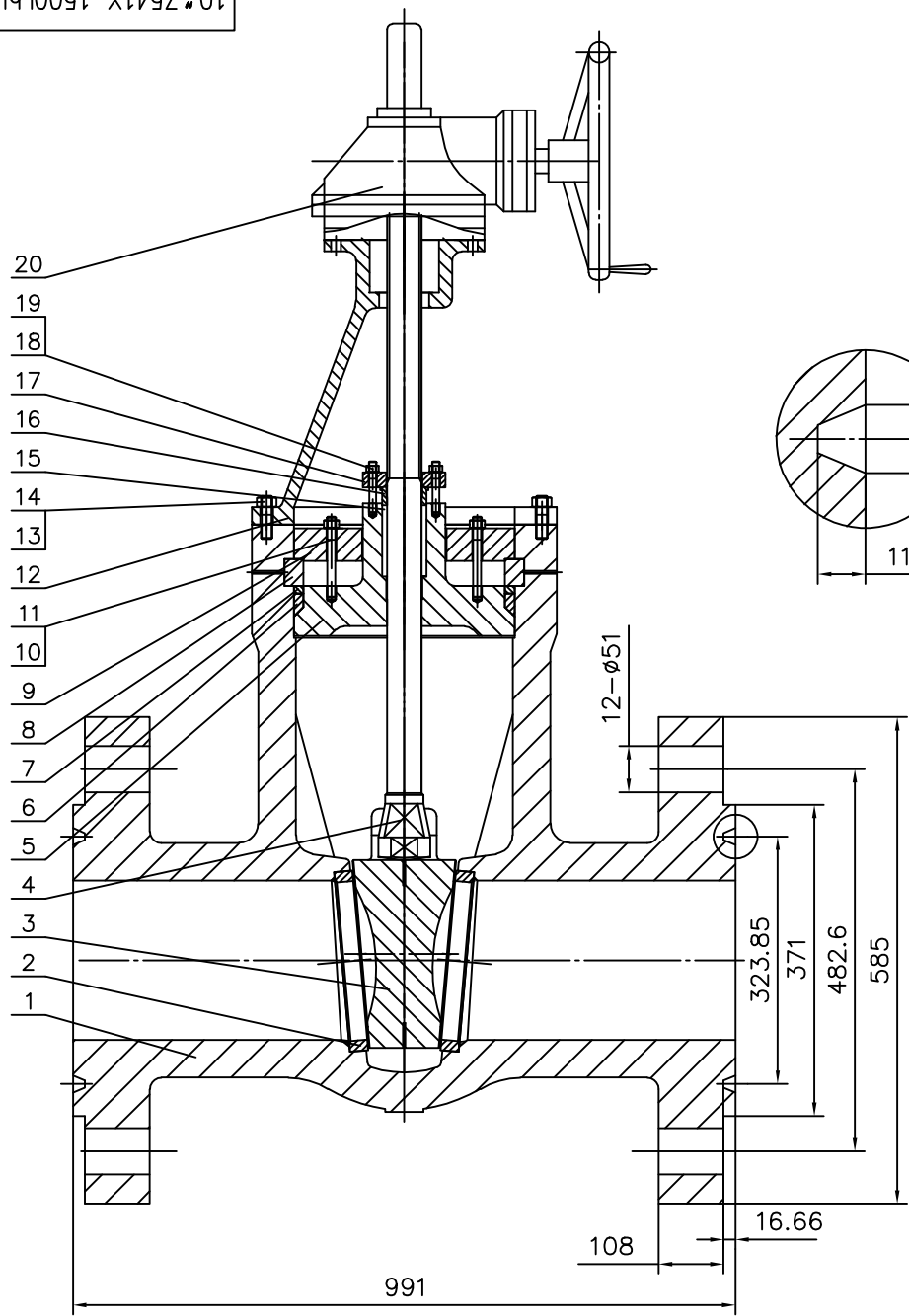

Performance		
	Pressure	1500Lb
Test	Shell	37.5
	Backseat	27.5
	Seat	27.5
	Air test	0.6
	Temperature	540 °C
	Medium:	Gas,oil

- Requirments
- 1.Design and manufacture as per API600;
 - 2.Pressure-temperature rate as per ASME B16.34
 - 3.Inspection and test as per API598;

Item	Part Name	Material	Weight	Remark
20	Worm gear			
19	Nut	A194 2HM		
18	Bolt	A193 B7M		
17	Gland flange	35CrMo		
16	Gland	2Cr13		
15	Packing	Reinforcement Graphite		
14	Nut	A194 2HM		
13	Bolt	A193 B7M		
12	Yoke	A216 WCB		
11	Nut	A194 2HM		
10	Bolt	A193 B7M		
9	Plate	A182 F11		
8	ring	A182 F11		
7		A182 F11		
6	Gasket	Reinforcement Graphite		
5	Disc	A217 WC6		
4	Stem	A182 F11		
3	Wedge	A217 WC6+STL		
2	Seat	A182 F11+STL		
1	Body	A217 WC6		

ASSEMBLY DRAWING		GATE VALVE	
10" Z541Y-1500LbI-00		STV VALVE TECHNOLOGY GROUP	
Design Luo	Scale		
Check Roth	1:3		
Approved Jake			
Std. API 600	1 Page	1st Page	