

J61Y-PN63

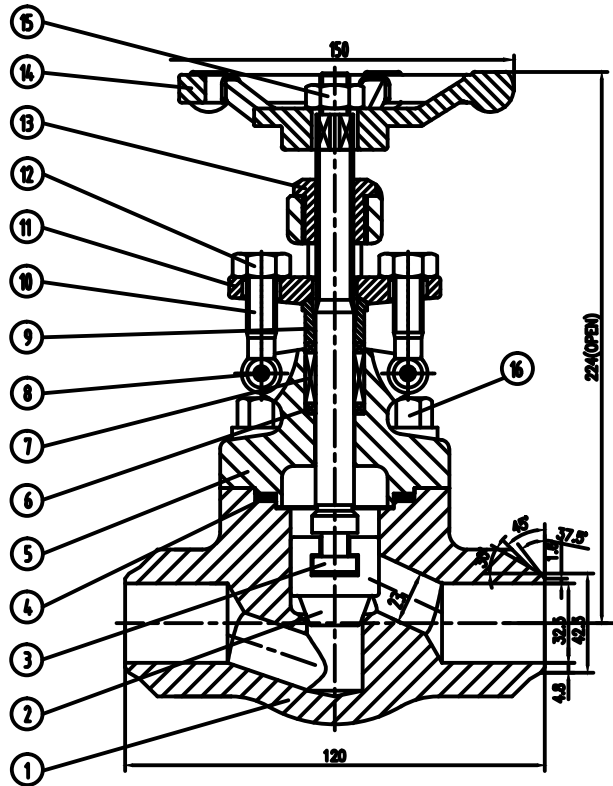

TEST ITEM	TEST PRESSURE(MPa)
SHELL LEST	9.5
BACK SEAT LEST	7
HIGH PRESSURE TEST	7
LOW PRESSURE TEST AIR SEAL	0.6

16	Bolt	35CrMo
15	Handwheel nut	35CrMo
14	Handwheel	DUCTILE IRON
13	Stem nut	35CrMo
12	Eyebolt nut	35CrMo
11	Gland flange	A105
10	Eyebolt	35CrMo
9	Gland	SS410
8	Pin	304
7	Packing	GRAPHITE
6	Packing	FLEXIBLEGRAPHITE
5	Bonnet	A105
4	Bonnet gasket	304+GRAPHITE
3	STEM	SS410
2	DISC	SS410
1	BODY	A105
	PART NAME	MATERIAL

BOLTED BONNET GLOBE VALVE,BUTT WELD END
SCH80,OUTSIDE SCREW CARBON STEEL BODY

FIG.J61H-63

32mm- PN63