

NPS-DN		Typical Dimensions				PN 2.5MPa Dimensions				WT
in	mm	L	H	W	-	BSPT	d	B	-	Kg
4	100	-	-	-	-	4"	100	33	-	-

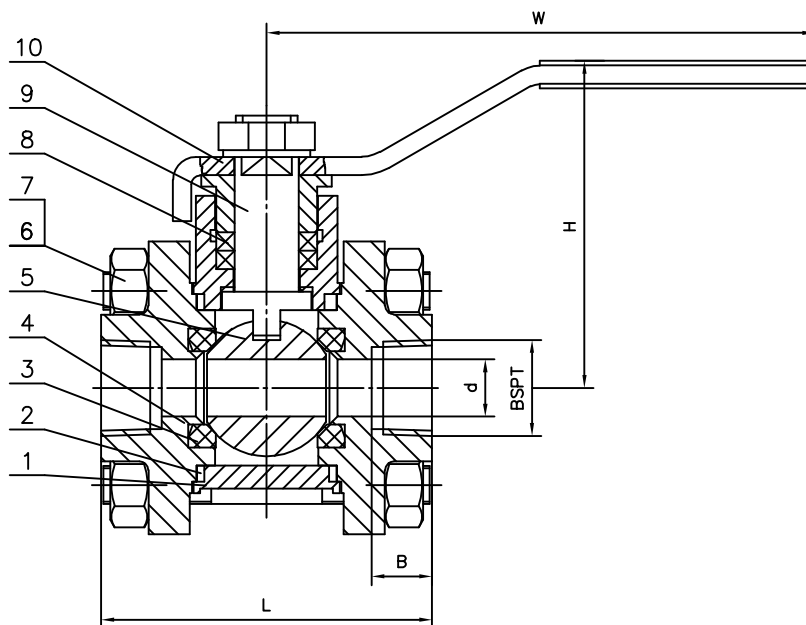

Notice:

1. Design by DIN 3352
2. BSPT ends by BS21
3. Valves tested by DIN 3230

			NO	REVISION	DATA	NAME
			STANDARD			
TEST PRESSURE	SHELL		SEAT			
	UNIT	Psig	Psig			
	HYDRAULIC					
			PNEUMATIC			
BALL VALVE						FIG NO
10	Handle	COMPONENT PART				
9	Stem	ASTM A182-F316				
8	Packing	PTFE				
7	Bonnet Bolt	ASTM A193 Gr.B7				
6	Bonnet Bolt Nut	ASTM A194 Gr.2H				
5	Ball	ASTM A182-F316	DESIGN BY	SITASIA SINGAPORE		
4	Cover	ASTM A216-WCB	CHECKED BY			
3	Seat Ring	PTFE	STANDARD BY	DRAWING NO	REV	
2	Gasket	PTFE	APPROVED BY	273WZG		
1	Body	ASTM A216-WCB				
NO	PART NAME	MATERIAL	REMARKS	THE USER CONFIRM	DATE	12/8/2007