

8T1008-19ZM

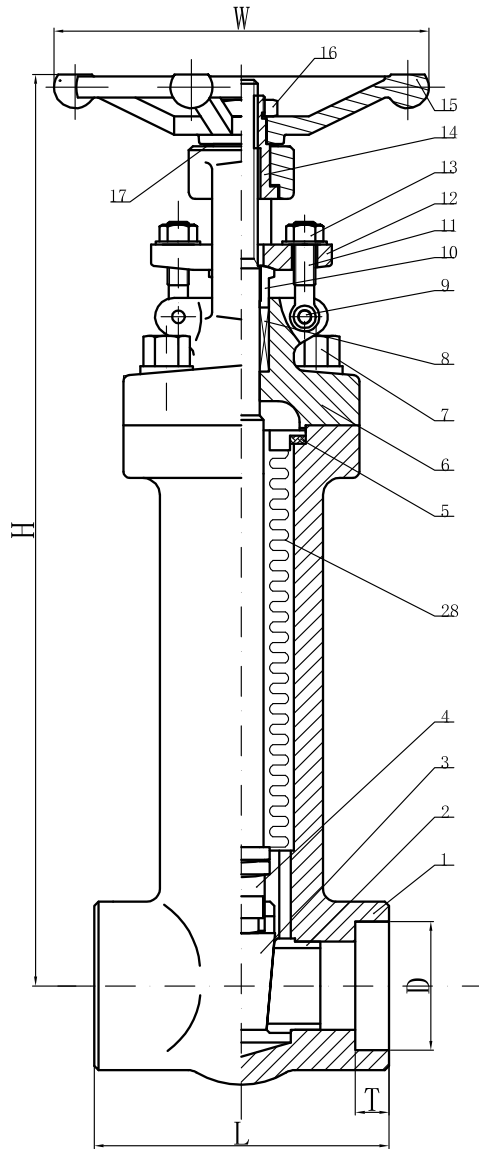

Technical Requirement

1. Design and manufacture to API 602
2. Face-to-face dimension to Mfr std
3. Ends Connection dimension to ASME B16.11
4. Inspection and test to API598

Performance Specification		
Nominal Pressure		14.0
Test Pressure	Shell Test	21.0
	Sealing Test	15.4
	Air Tight Test	0.7
Applicable Temperature		-29~425°C
Applicable Medium		Oil, Steam and Water

28	Bellow	1	304	
17	Lubricating gasket	1	410	
16	Locking nut	1	35#	
15	Handwheel	1	A197	
14	Stem nut	1	25#	
13	Hex nut	2	2H	
12	Gland flange	1	410	
11	Gland eyebolt	2	B7	
10	Gland	1	410	
9	Pin	2	304	
8	Packing	1	Graphite	
7	Bolt	4	B7	
6	Bonnet	1	A105N	
5	Gasket	1	304+graphite	
4	Stem	1	F6	
3	Wedge	1	410+STL	
2	Seat	2	13CR+STL	
1	Body	1	A105N	
No	PARTS NAME	QTY	Material	

3/4"	92	2.7	27.1	285	100
NPS	L	T	D	H	W

BELLOW GATE VALVE