

Technical Requirements

1. Design & Manufacture conform to API 602
2. Face to Face to factory standard
3. Flange ends conforms to ASME B16.5
4. Test & Inspect conform to API 598

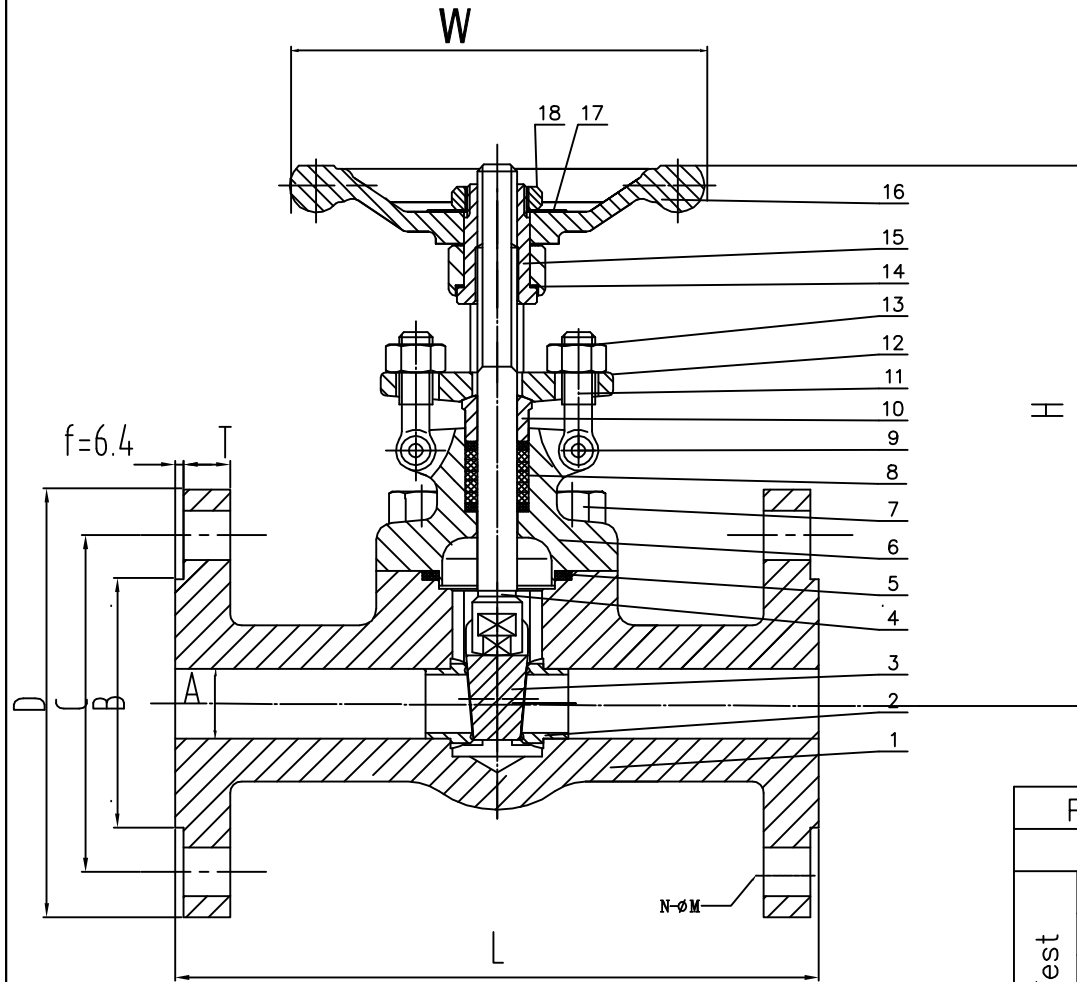

18	Flat Nut	1035+Zin
17	Nameplate	304
16	Handwheel	A197
15	Stem Nut	A194 4
14	Gasket	316+Graphite
13	Hex Nut	A194 4
12	Gland Flanged	F11
11	Eye Bolt	A193 B16
10	Gland	410
9	Pin	304
8	Packing	Graphite
7	Bolt	A193 B16
6	Bonnet	F11
5	Gasket	304+Graphite
4	Stem	F6A
3	Disc	410+STL
2	Seat	410+STL
1	Body	A182 F11

Performance List		
Class		1500LB
Test	Shell Test	27.5
	Back seal Test	23.1
	Seal Test	
	Air Seal	0.6
Temp.	≤540°C	

SIZE		A	B	C	D	M	H (OPEN)	W	L	N	T
INCH	MM										
1 1/2"	40	40	73	123.8	178	29	296	200	305	4	32

No.	Name	Material
-----	------	----------

Gate Valve				FIG NO	
DESIGN					
CHECKED					
STANDARD				DRAWING NO	REV
APPROVED					